

8.5T – 10T Hydraulic Drive Unit

Belt Replacement / Tensioning Procedure

Theory:

V-Belts operate on friction. Too little tension results in slippage and excessive heat and wear. The proper tension for a V-belt is the lowest tension at which the belt won't slip or squeal under peak load. Always tension belts to the manufacturer's recommendations.

NOTE: Always ensure hydraulic power to unit is locked-out prior to performing any work.

To tension belt, adjust the center distance until the belt appears taut. At the center of the belt span, apply a force perpendicular to the belt. Measure the force required to deflect the belt $1/64$ " per inch of span length. For example, an 8" span requires a $1/8$ " deflection. Compare the force required to the manufacturer recommended range.

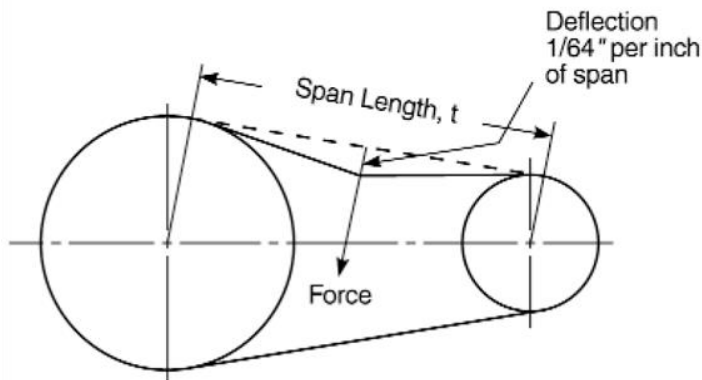

Alternately, adjust the center distance until the belt appears taut. Run the drive for about 15 minutes to seat the belt and apply full load. If the belt slips or squeals, apply more tension. When the drive is in motion, a slight sag on the slack side is normal. This method of belt tensioning, without measuring force or deflection, is inaccurate and can cause damage to equipment and/or personnel. Please follow manufacturer recommended procedures.

Removing Belts:

1. Loosen belt-tensioning-arm bolts (2).
2. Loosen locking bolts (4).
3. Loosen belt tensioning bolts (2).

Tensioning Belts:

1. Ensure belts are properly aligned in pulley grooves.
2. Tension compressor drive belt by tightening belt tensioning bolts (2). Tighten both bolts evenly until the belt is properly tensioned. (Deflection approximately 3/16" with 10.5 Lb load)
3. Tighten locking bolts (4).
4. Tighten water pump drive belt tensioning arm:
 - a. Use ½" drive socket wrench to push the tensioning arm idler pulley into the belt – creating the desired tension.
 - b. Once in place, tighten the belt-tensioning-arm bolts (2).
 - c. Belt is tight when deflection = 1/8" with 10.5 Lb load.

Reference Values

Belt	Span	Deflection	Force
6PK	8"	1/8"	10.5 Lbs
6PK	10.5"	3/16"	10.5 Lbs

NOTE:

Whenever working on machinery, it is best practice to take note of the condition of all inclusive components. For the belt drive system, be sure to check wear on the pulleys, belts, and idler bearings. Also check for free rotation of water pumps while belts are off, and free rotation of clutches when disengaged.

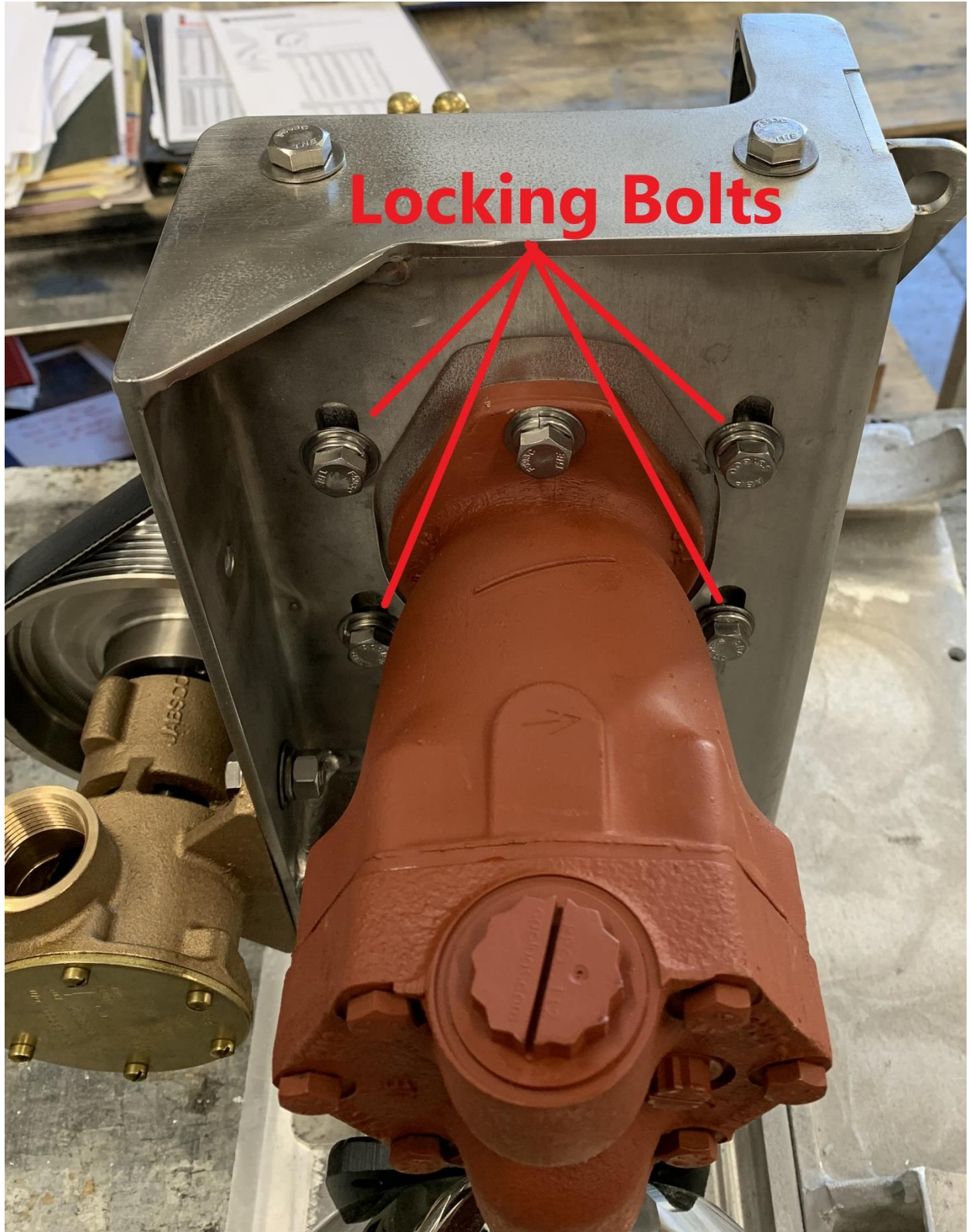

Locking Bolts



**BELT
TENSIONING
BOLTS**

**Tensioning-
Arm Bolts**

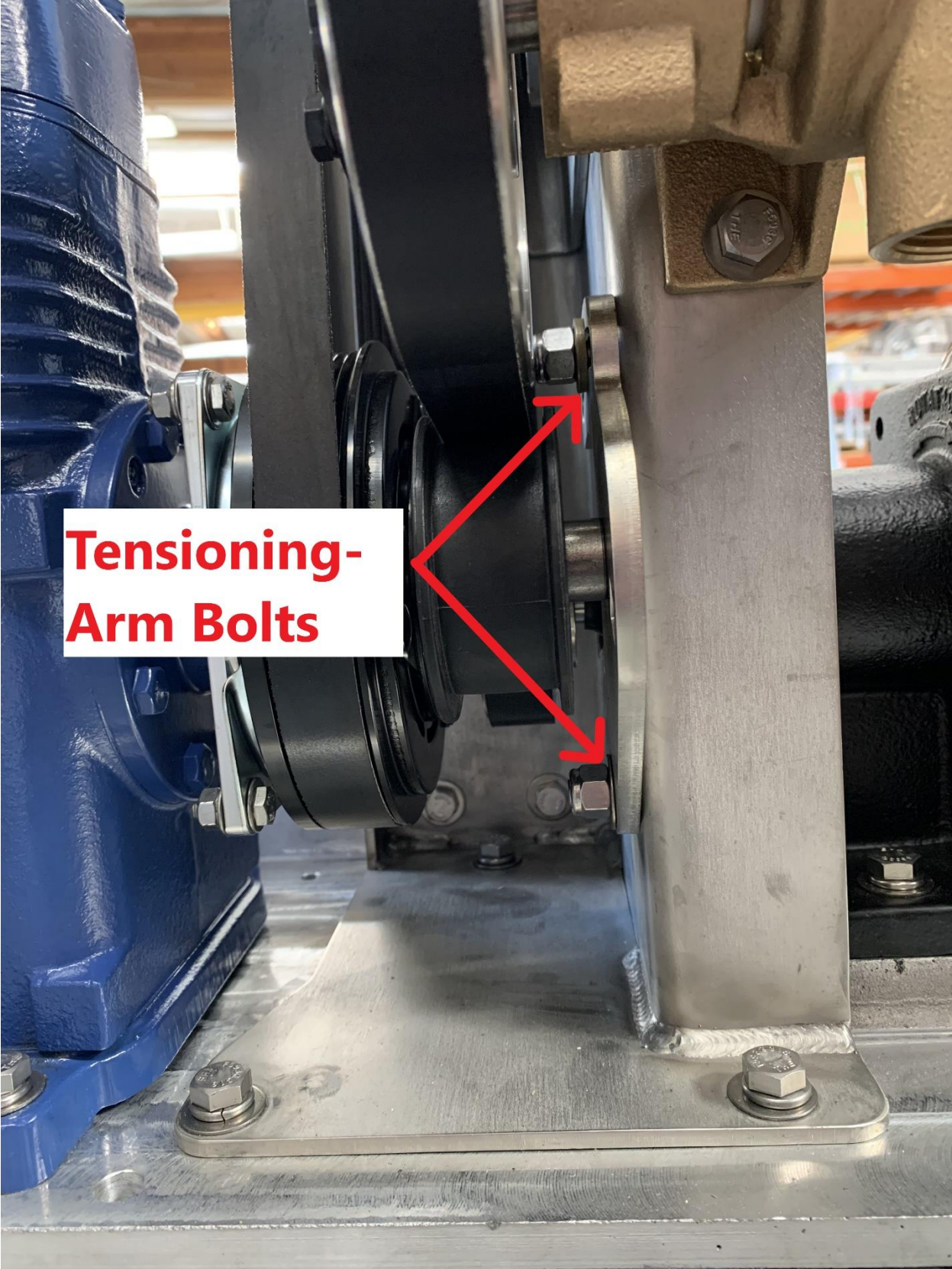

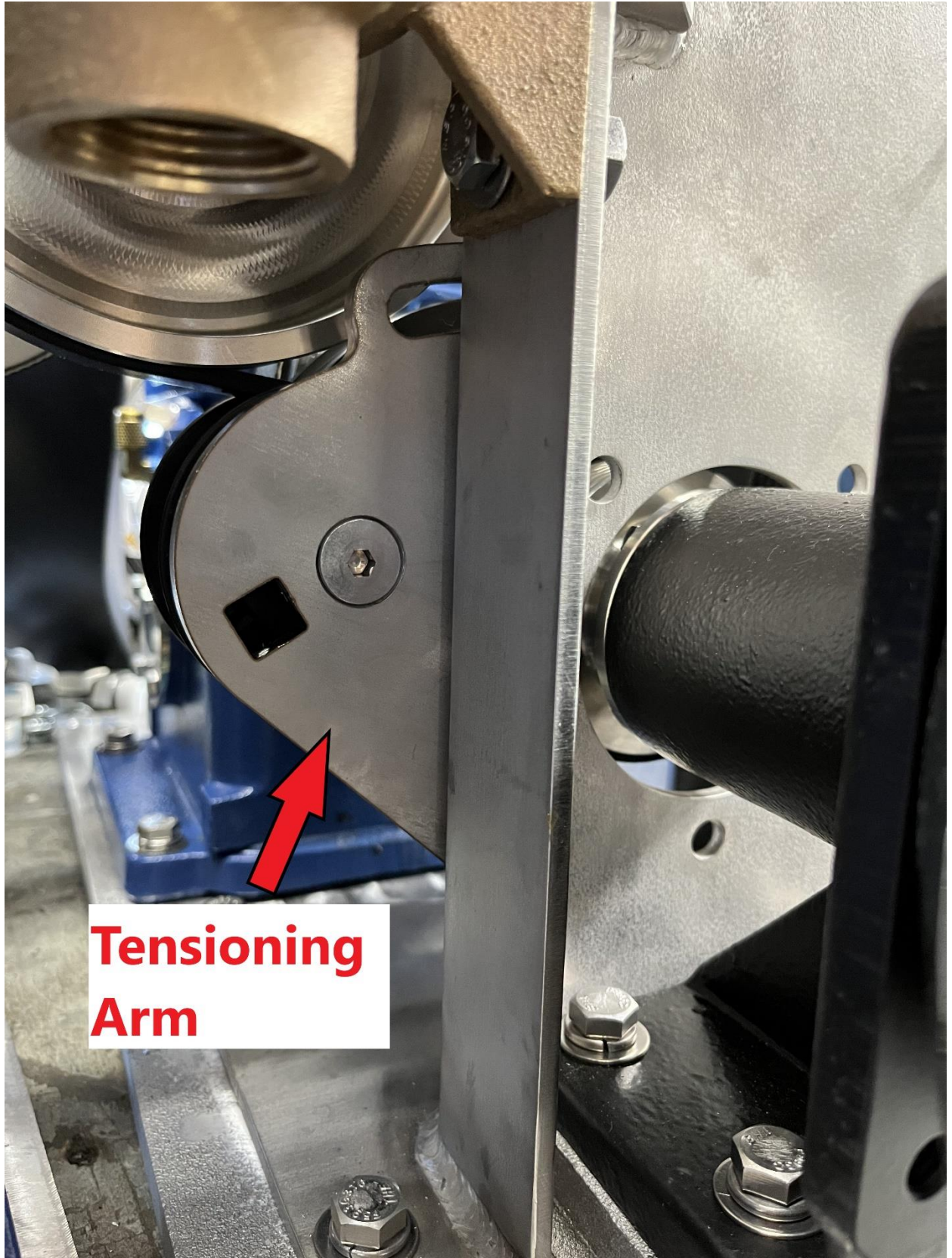

**Tensioning
Arm**